



REPLACEMENT TONER CARTRIDGE

USER MANUAL



## UBRS

## PRODUCT FEATURES:

Thank you for selecting UBRS Replacement printer consumables. This product is a well-designed alternative to replace your original cartridge; it provides stable printing performance that suits your needs. Before you use, please read this instruction carefully and follow the steps below to install, use and to ensure the high quality of printing.

## SETTING UP AND USING:

1. Turn off the printer, remove the empty toner cartridge
2. Use a soft cloth slightly moistened with alcohol to clean the toner cabinet.
3. Take the toner cartridge from sealed package; dispose the used toner cartridge properly.
4. Hold both ends of the UBRS toner cartridge horizontally, shake gently for about 5 to 6 times, this can help loosen toner powder.
5. Place the toner cartridge horizontally on the table with the protection cover side up, pull the seal out gently small amount of toner powder may leak in this process
6. Pull out the stain prevention paper, install toner cartridge into the printer and close the lid
7. Turn on the printer and start to use

## SAFETY INFORMATION:

1. Slight powder leakage may occur due to vibration during shipment, please clean up with a soft dry cloth.
2. Never disassemble the cartridge and touch any internal components, it may affect printing quality.
3. Avoid high temperature, high humidity, strong magnetic field or direct sunlight.
4. This product can achieve best printing performance by using ordinary neutral copy paper, 70 to 90 grams.
5. Optimal Usage requirements:  
 Temperature: 15 ~ 35 deg,  
 Relative humidity: 50% to 80%,  
 Altitude: 0 ~ 3048m.
6. Optimal Storage and Transportation requirements:  
 Temperature: 5 ~ 40 deg,  
 Relative humidity: 30% to 90%,  
 Altitude: 0 ~ 3048m.
7. Keep out of reach of children

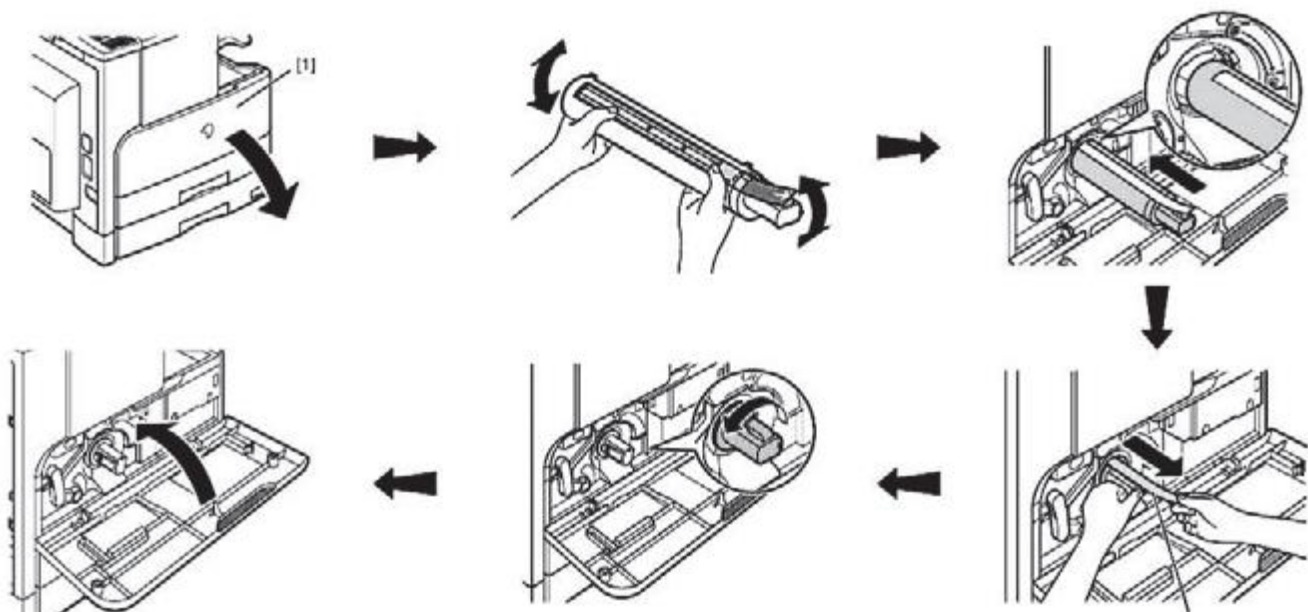

## MAINTENANCE:

Before looking for official warranty service, users may be able to solve some problems by themselves.

## TONER CARTRIDGE TROUBLESHOOTING:

NO.	DESCRIPTION	REASONS	SOLUTIONS/ACTION
1	Small amount of toner powder leakage may occur	Some toner powder of the toner cartridge may leak during QC inspection in factory or during transportation	Safe to use
2	Poor printing performance, uneven color distribution on printouts when first use	Cartridge component lubricating oil spread on the OPC during cartridge assembly or QC inspection.	This phenomenon will vanish after printing several times.
3	Colors on printouts - very light.	Improper printing paper, too thick. Internal components failure.	Replace with thinner paper. Repair the printer.
4	Cartridge is noisy while printing.	When start-up, the cartridge is relatively noisy, this is normal.	Safe to use.
5	A thin layer of dust on printouts.	A thin layer of dust on printouts. Prolonged storage in box before first use.	Clean the cartridge cabinet. This phenomenon will vanish after printing several times.
6	A thin layer of dust on printouts.	Tiny amount of toner powder leakage.	Clean the cartridge cabinet with a cloth.
7	Full-page black or blank printouts.	Toner cartridge is not properly inserted. Internal circuits of laser printer are damaged.	Re-insert the cartridge. Repair the printer.
8	The printer cannot detect toner cartridge.	The printer is not zero-cleared. The toner cartridge is not properly inserted.	Use zero-clear function is the printer according to printer user manual.  Re-insert the cartridge
9	Full-page or half-page printouts.	Component PCR is not adequately charged.	Restart and reprint several times. Contact supplier or warranty service if problem persists.

## SOCIAL RESPONSIBILITY:

PLR IP Holdings, LLC, its licensees and affiliates, fully supports all electronic waste initiatives. As responsible stewards of the environment, and to avoid violating established laws, you should properly dispose of this product in compliance with all applicable regulations, directives of other governances in the area where you reside. Please check with local authorities of the retailer where you purchased this product to determine a location where you can appropriately dispose of the product. You may also go to [www.UBRS.com](http://www.UBRS.com) and reference Social Responsibility <http://www.UBRS.com/social-responsibility> to learn more about the specific laws in your area and to locate a collection facility near your home This Product as supplied and distributed new by an authorized retailer is warranted by Daisytek Computers LLC., to the original consumer purchaser against defects in material and workmanship (“Warranty”) for a period of one (1) year from the date of purchase. To receive Warranty service, the original consumer purchaser must contact the point of purchase for problem determination and service procedures. Proof of purchase in the form of a bill of sale or receipted invoice, evidencing that the Product is within the applicable Warranty period(s), MUST be presented in order to obtain the requested service.

## EXCLUSIONS AND LIMITATIONS:

Shipping expenses incurred to ship your product to a service centre or Return Facility are not covered by this warranty, and must be paid by the purchaser. This Warranty covers manufacturing defects in materials and workmanship encountered in the normal, non-commercial use of the Product, and does not cover consumer instruction, delivery, installation, set-up, adjustments, cosmetic damage or damage due to acts of nature, accident, misuse, abuse, negligence, commercial use or modification of, or to any part of the Product. This Warranty applies to the original consumer only and does not cover products sold AS IS or WITH ALL FAULTS, sold as Reconditioned, or refurbished or Re-manufactured. This Warranty is valid only in the country where the consumer purchased the product, and only applies to products purchased and serviced in that country

NO WARRANTIES, WHETHER EXPRESS OR IMPLIED, INCLUDING, BUT NOT LIMITED TO, ANY IMPLIED WARRANTIES OF MERCHANTABILITY OR FITNESS FOR A PARTICULAR PURPOSE, OTHER THAN THOSE EXPRESSLY DESCRIBED ABOVE SHALL APPLY. DISTRIBUTOR FURTHER OTHER EXPRESS WARRANTY OR GUARANTY GIVEN BY ANY PERSON, FIRM OR ENTITY WITH RESPECT TO THE PRODUCT SHALL BE BINDING ON DISTRIBUTOR. REPAIR, REPLACEMENT, OR REFUND OF THE ORIGINAL PURCHASE PRICE - AT DISTRIBUTOR’S SOLE DISCRETION-ARE THE EXCLUSIVE REMEDIES OF THE CONSUMER. IN NO EVENT WILL DISTRIBUTOR, ITS MANUFACTURERS, OR PLR IP HOLDINGS, LLC BE LIABLE FOR ANY INCIDENTAL, DIRECT, INDIRECT, SPECIAL, PUNITIVE OR CONSEQUENTIAL DAMAGES (SUCH AS, BUT NOT LIMITED TO DAMAGES FOR LOSS OF PROFITS, BUSINESS, SAVINGS, DATA OR RECORDS) CAUSED BY THE USE, MISUSE OR INABILITY TO USE THE PRODUCT. EXCEPT AS STATED HEREIN, NO OTHER WARRANTIES SHALL APPLY. NOTWITHSTANDING THE FOREGOING, CONSUMER’S RECOVERY AGAINST DISTRIBUTOR SHALL NOT EXCEED THE PURCHASE PRICE OF THE PRODUCT SOLD BY DISTRIBUTOR. THIS WARRANTY SHALL NOT EXTEND TO ANYONE OTHER THAN THE ORIGINAL CONSUMER WHO PURCHASED THE PRODUCT AND IS NOT TRANSFERABLE.

Some countries or provinces do not allow the exclusion or limitation of incidental or consequential damages or allow limitations on warranties, so limitation or exclusions may not apply to you. This warranty gives you specific legal, and you may have other rights that vary from state to state or province to province Contact your authorized retailer to determine if another warranty applies. UBRS, UBRS & Pixel, UBRS Color Spectrum and UBRS Classic Border Logo are trademarks of PLR IP Holdings, LLC, used under license. PLR IP Holdings, LLC does not manufacture this product or provide any Manufacturer’s Warranty or support. This product is distributed by Daisytek Computers LLC © 2018 All Rights Reserved.

100% SATISFACTION GUARANTEE IF YOU ARE NOT COMPLETELY SATISFIED WITH THIS PRODUCT, WE WILL EXCHANGE FOR ANOTHER PIECE OR PRODUCT – OR CREDIT YOUR PURCHASE PRICE. NO QUESTIONS ASKED. OUR GOAL IS THAT YOU SHOULD BE 100% SATISFIED WITH YOUR PURCHASE. IF YOU ARE NOT, WE WILL DO WHATEVER WE CAN TO TRY AND CHANGE THAT.